



# 20-24 APRIL 2024 NOTICE OF RACE

## Organizing Committee



**LNI sez. Cagliari**



**YC Porto Rotondo**



**YC de Monaco**



REGIONE AUTONOMA  
DE SARDIGNA  
REGIONE AUTONOMA  
DELLA SARDEGNA

con il Patrocinio della Regione Sardegna



COMUNE DI CAGLIARI

con il Patrocinio del Comune di Cagliari

## 1 ORGANIZATION AUTHORITIES

Lega Navale Italiana sezione Cagliari, Yacht Club Porto Rotondo and Yacht Club de Monaco are the organizing authority (OA) under the aegis of the Italian Sailing Federation (FIV).

Web: [www.cagliarimonaco.org](http://www.cagliarimonaco.org)

email: [segreteria@cagliarimonaco.org](mailto:segreteria@cagliarimonaco.org)

## 2 REGULATIONS

2.1 The event will be governed by the current version of the following rules:

- a. The rules as defined in the Regatta Regulations (RRS); RRS 90.3(e) applies.
  - b. Offshore Special Regulations (OSR) Category 3 with mandatory self-inflating raft;
  - c. FIV Offshore Regulations [note: it is compulsory for each crew member to wear a personal flotation device (PFD) equipped with a waterproof torch from 2000 to 0530 CEST];
  - d. IMS-ORC Regulations.
1. And. IRC Rules, parts A, B and C;
  2. and.1. IRC Rule 22.4.2 is deleted and replaced with:
  3. "The maximum number of crew members on board must correspond to the crew number shown on the certificate. There is no weight limit."
    - e. IMA class rules (only for Maxi Yachts);
    - f. The rating used for Multihulls in 2023 will be ORC.mh; mocra.
    - g. This Notice of Race and any amendments.
  4. The OA reserves the right to modify this BdR up to two hours before the start of the regatta, by publishing the new version on the event website and also by sending it to already registered yachts. Such notification shall be deemed to comply with RRS 89.2(a).
  5. the. Sailing Instructions and any amendments.

2.2 From 2000 to 0530 CEST, the rules of Part 2 of the RRS will not apply and will have to be replaced by the International Standards for Preventing Collisions at Sea (NIPAM).

2.3 This paragraph only applies to Maxi Yachts:

- a. Canting keels, movable appendages and water ballasts are permitted if declared on the measurement or class certificate. This modifies RRS 51.
- b. Steering, ram and winch systems using non-manual power are permitted. This modifies RRS 52.
- c. Electrical or electronic devices of any kind are permitted but shall not be used to steer or operate the vessel's navigational systems including appendages independently except in an emergency or as permitted by class rules.
- d. Exceptions to RRS 77 may be granted by the OA upon request presented in writing before the deadline for registration. This modifies RRS 77.

2.4 The official languages of the regatta are English and Italian. In the event of a conflict between the two languages, the English text will prevail.

## 3 SAILING INSTRUCTIONS

- 3.1 The Sailing Instructions will be available, in English and Italian from 01/04/2024 at:  
[www.cagliarimonaco.org](http://www.cagliarimonaco.org) and  
<https://www.racingrulesofsailing.org/documents/5480/event>

## 4 COMUNICAZIONI

- 4.1 The Official Online Bulletin Board (ONB) can be found at  
<https://www.racingrulesofsailing.org/documents/5480/event>
- 4.2 **[DP]** All boats shall have on board a VHF radio transmitting on channels: 14, 16, 74.
- 4.3 All communications with participants will take place through the VHF channels indicated in the Sailing Instructions, published on the online ONB, by e-mail, and/or WhatsApp or Telegram
- 4.4 **[DP]** Each vessel shall have at least one internet connected device with WhatsApp/Telegram installed.
- 4.5 **[DP]** While racing, except in an emergency, a boat shall not make voice or data transmissions and shall not receive voice or data communications which are not available to all boats.

## 5 ADMISSION TO RACE

- 5.1 Vessels with a LH  $\geq$  9.00 m with a valid measurement/class certificate are permitted:
- ORC (International or Club): divided into groups A and B as per FIV Offshore Regulations;
  - IRC: with LH < 18.29m, the class may be divided at the discretion of the TC, the division will be published on the ONB as soon as possible after the deadline for entries.
  - Maxi Yachts: LH  $\geq$  18.29m IRC rating;
  - Class 40;
  - Monotypes;
  - Multihulls;
  - Classic Yachts
- 5.2 Eligible boats may participate in ONLY one (1) rating class.  
CLARIFICATION: A boat that has both ORC and IRC rating certificates will have to choose whether to race with an ORC or an IRC certificate.
- 5.3 After the deadline for entries (BdR 5.4), a boat can submit a request to the OA to change her rating class (from ORC to IRC and vice versa), no later than 48 hours before the signal start of the regatta. The request must be submitted in writing providing a valid reason for the change request as well as all the necessary documents. The decision will be at the discretion of the TC.
- 5.4 Eligible boats may enter by completing the online entry form by 2400 04/21/2023 and sending the required entry fee to:

**Circolo Lega Navale Italiana sezione di Cagliari**  
**IBAN: IT85N010150480000000022254 - BIC:SARDIT3S**  
**Indirizzo: viale Colombo 135,**  
**09125 Cagliari, Italy**

**email:segreteria@cagliarimonaco.org**

The following documents should be included:

- a. A valid measurement/class 2023 certificate.
  - b. Crew List (<https://www.racingrulesofsailing.org/documents/5480/event>)
  - c. At least one (1) crew member, valid WS Offshore Personal Survival Training Course certificate for every 7 people
  - d. FIV 2024card of each crew member (For foreign crews see, BdR 7.2);
  - e. Crew list with handicap as per FIV Offshore Regulations 2023, if applicable;
  - f. Minors form (link <https://www.racingrulesofsailing.org/documents/5480/event>) for all participants under the age of 18 (BdR 7.4);
  - g. Adequate insurance coverage for civil liability towards third parties, with a minimum coverage of Euro 1,500,000.00;
  - h. Advertising license if applicable.
  - i. Risk acknowledgment form, in accordance with RRS 3, signed by all crew members; link <https://www.racingrulesofsailing.org/documents/5480/event>
  - j. Liability Release Form at the link <https://www.racingrulesofsailing.org/documents/5480/event> concerning the mandatory safety equipment in accordance with the current Category 3 of the WS OSR with the obligation of a self-inflating raft and personal flotation devices (PFD) equipped with a waterproof flashlight;
- 5.5 The nationality registration of a vessel must be indicated on the entry form. If not indicated, the letters preceding the sail number (on the mainsail) or the owner's nationality will be used.

## 6 REGISTRATION FEE AND SECURITY DEPOSIT

6.1 The registration fees are as follow:

Hull Lenght (LH)	Early Bird - <i>before 2400 del 31/03/2024</i>	<i>from 01/04/2024</i>
Up a 45'	Euro 300,00	Euro 350,00
from 46' to 59'	Euro 400,00	Euro 450,00
from 60' to 69'	Euro 500,00	Euro 650,00
from 70' and above	Euro 600,00	Euro 650,00

Owners who are members of the organizing clubs are entitled to a 10% discount.

**A boat that has not paid the entry fee will not be considered formally entered.**

6.2 Security deposit for the Tracking Unit

- a. An electronic tracking system will be used to monitor the nautical position of the vessels. More information about the tracking system will be present in the SI.
- b. Each owner/skipper will be asked for a security deposit of Euro 100 agreement. The deposit will be returned upon return of the instrument, provided it is in perfect condition, to the YCM regatta office. Any damages will be charged to the owner/skipper.

## 7 CREW AND MEMBERSHIP REQUIREMENTS

- 7.1 All Italian crews must have a FIV 2024 card (with a valid medical examination).
- 7.2 Foreign crews will have to respect the rules established by their national authorities.
- 7.3 Participants must be 14 years old at the start of the regatta.
- 7.4 Participants under the age of 18 must present the minor authorization form upon registration.

## 8 ADVERTISING

- 8.1 Vessels may be required to display advertising selected and supplied by the OA.
- 8.2 All Italian boats must present the FIV advertising license, if applicable, at registration.
- 8.3 Foreign vessels will have to comply with the advertising rules set by their national authorities, if applicable.
- 8.4 Vessels intending to display advertising while racing, whether or not a racing yacht, support vessel, or ashore within the regatta area, shall indicate the nature of such advertising on the entry form. The OA may refuse membership or withdraw membership if the advertisement does not comply with the World Sailing Advertising Code.

## 9 PROGRAM

- 9.1 The official time of the event is CEST GPS TIME.
- 9.2 The preliminary program and timeline is as follow:

<b>Thursday 18 Aprile</b>		<b>Arrival of the boats at Portus Karalis, Controls and entries</b>
<b>Friday 19 Aprile</b>	<b>0900 – 1700 1100  1700  1900</b>	<b>Controls and entries Press conference, location TBA  Skippers' Meeting (see ONB)  Skipper sand crews aperitive (see ONB)</b>
<b>Saturday 20 Aprile</b>	<b>0700-1100 1200</b>	<b>Preparations and cast off Starting signal of Cagliari-Monaco</b>
<b>Wednesday 24 Aprile</b>	<b>1700 1900</b>	<b>Arrival time limit Prize giving ceremony at Yacht Club de Monaco</b>
<b>Thursday 25 Aprile</b>	<b>1100</b>	<b>Cast off from YCM</b>

## 10 EQUIPMENT AND MEASUREMENT CHECKS

- 10.1 Each yacht must be in possession of a valid measurement/class certificate issued before 1500 on 19/04/2024.
- 10.2 The Technical Committee (TC) may inspect a boat before and after the race.
- 10.3 [DP] The owner / skipper shall complete and sign the Disclaimer Form relating to the vessel in which you declare that all safety equipment is on board and that the yacht complies with the measurement requirements. The Form must be presented to the regatta office before/within the registration period and can be downloaded from the following link:  
<https://www.racingrulesofsailing.org/documents/5480/event>

## 11 THE OFFICES

### 11.1 Regatta offices:

- a. In Cagliari at the headquarters of the Italian Naval League, Cagliari section, viale Colombo 135, 09125 Cagliari  
Phone: +39 340 7631845 (Sport Director) Email: [segreteria@cagliarimonaco.org](mailto:segreteria@cagliarimonaco.org)
- b. In Monte Carlo at the Yacht Club de Monaco.  
Phone: +377 93 10 65 05 (YCM) Email: [regates@ycm.mc](mailto:regates@ycm.mc)
- c. Race Direction / Race Director: +39 335 7015959 - +39 340 7631845  
Email: [rc@cagliarimonaco.org](mailto:rc@cagliarimonaco.org)

## 12 ROUTE OF THE RACE

- 12.1 The regatta will be carried out between the Gulf of Cagliari and the Bay of Monaco. The departure gate will be located south of the Levante breakwater of the port of Cagliari, the boats will have to round the Sella del Diavolo cape and proceed towards the Poetto buoy which must be kept to the right, see attachment A of the notice and SI
- 12.2 A natural flying gate is located near Porto Rotondo (northern Sardinia) between the cardinal buoy of Punta Volpe and the southernmost point of Soffi island, which must be kept to the right, see attachment B of the announcement and SI. At this gate the times will be taken and used in case of force majeure.
- 12.3 After the gate free route to Montecarlo
- 12.4 The route will be described in the SI with the relative details.

## 13 PENALTY SYSTEM

- 13.1 If a boat believes that she has broken a rule of Part 2 of the RRS or NIPAMs (as they apply) against another boat entered in this Regatta, she may exonerate herself by promptly taking a One-Turn Penalty including a tack and one shot down in the same direction. This modifies RRS 44.1 and 44.2.
- 13.2 If a boat takes a penalty, she must enter the time and place on the FORMS at the following LINK <https://www.racingrulesofsailing.org/documents/5480/event>
- 13.3 An International Jury will be appointed in accordance with RRS 91, all decisions will be final in accordance with RRS 70.5.

## 14 SCORE

- 14.1 To calculate the results of monohulls and multihulls, a software chosen by the TC among the official ones will be used. Different interpretations cannot be the object of a request for repair. **This changes RRS 62.1(a).**
- 14.2 The scoring option chosen by the TC, in relation to the ORC Monohull Class, will be among those based on the "Time on Distance" method.  
The scoring option chosen by the TC, in relation to the IRC Monohull Class, will be among those based on the "Time on Time" method.  
Different interpretations cannot be the object of a request for repair. This changes RRS 62.1(a).
- 14.3 The scoring option chosen by the TC, in relation to the ORC Multihull Class, will be among those based on the "Time on Distance" method.  
Different interpretations cannot be the object of a request for repair. **This changes RRS 62.1(a).**

## 15 SUPPORT VESSELS

- 15.1 **[DP]** Support vessels shall be registered with the OA and marked with the official flag provided by the OA.

## 16 DRONES OF THE PARTICIPANTS

- 16.1 **[DP]** Crews or other boat support personnel may not fly over the Cagliari-Monaco land areas or the regatta area with drones during training or regatta days without complying with local legislation and without prior written approval of the OA.
- 16.2 Approval, given at OA's sole discretion, may impose restrictions on where and when drones may be flown.
- 16.3 At any time the risk and responsibility for the flight of a drone is borne by the person who pilots it and the images taken within the regatta area must be shared with the Organizing Authority, the Race Committee or the International Jury following a reasonable request.
- 16.4 Drone flights are not allowed in Monaco without authorization which can be obtained by contacting the YCM office [presse@ycm.org](mailto:presse@ycm.org)

## **17 MOORING AND SERVICES**

### **17.1 Moorings in CAGLIARI**

The boats will be moored at the Portus Karalis Marina under the responsibility of the owner or skipper from Wednesday 17th April 2024 until the start of the regatta.

Vessels wishing to arrive at the Marina di Portus Karalis before 17th April 2024 must inform the Regatta Office by email to obtain the discount.

### **17.2 Moorings in Montecarlo**

The boats will be moored, free of charge, at the Port Hercule, Yacht Club de Monaco, under the responsibility of the owner or skipper, from their arrival until 1100 on 24/04/2024

Vessels wishing to stay longer will need to obtain authorization from the Yacht Club de Monaco Marina Desk by email: [assistante.marina@ycm.org](mailto:assistante.marina@ycm.org).

### **17.3 Transportation service**

The OA will be able to organize a transport service from the Portus Karalis Marina to YCM to transfer any baggage, the bags of the crews and the materials of respect of the boats; it is expressly mandatory to inform the tender secretariat to request the service.

b. It is important and mandatory to confirm the need for this service at the same time as registering, it will be the OA's responsibility to send the estimate. The goods will be delivered at the boat location.

## **18 RESTRICTIONS FOR TOWING AND DIVING**

18.1 [DP] During the event, boats shall not be hauled except with and under the terms of the prior written authorization of the RC or TC.

18.2 In accordance with Italian maritime law, it is strictly forbidden to dive while in the Marina of Portus Karalis.

18.3 In accordance with Monaco maritime law, diving while in Port Hercule is strictly prohibited.

## **19 DATA PROTECTION**

19.1 By entering the event, entrants automatically grant to the OA and their sponsors, the right in perpetuity, without compensation, to make, use and display, from time to time in their discretion, any live, recorded film and television or filmed and other reproductions of the athletes during the competition period.

19.2 Competitors may be asked to be interviewed during the event.

## **20 LIABILITY STATEMENT**

20.1 In accordance with World Sailing RRS Fundamental Rule 3: "responsibility for a boat's decision to participate in a race or to continue racing rests with her alone". By participating in this event each competitor accepts and acknowledges that sailing is a potentially dangerous activity with inherent risks. These risks include high winds and rough seas, sudden changes in weather, equipment failure, vessel handling errors, poor sailing technique by other vessels, loss of balance on an unstable platform and fatigue resulting in increased risk of injuries. Inherent in the sport of sailing is the risk of permanent and catastrophic injury or death from drowning, trauma, hypothermia or other causes.

The OA, the RC, the IJ and the TC decline all responsibility for any damage to persons and/or property, both on land and at sea, as a result of their participation in the regatta according to these instructions. Shipowners and skippers on board are reminded that they will have to personally answer for all the accidents that may happen to their boats and/or their crews. Therefore, shipowners and skippers will have to take out the necessary insurance to cover all risks including those against third parties. Owners and skippers are also responsible for the decision to take part in the regatta based on the strength of the wind, the state of the sea and the weather forecast. The Regatta, according to current regulations, does not have personal assistance except in the event of an emergency, for which the Maritime Authority (Port Authority) is responsible. For this reason all vessels must have a VHF radio capable of transmitting and receiving on channels 14, 16 (distress channel) and 74.

As a result of a behavioral or sportsmanship violation, the IJ may take disciplinary action. This applies throughout the event on land and at sea. The owner or his representative is responsible for the behavior of the crew.

In addition, all attendees, including officers, volunteers and others, are advised that they participate in this event solely at their own risk and voluntarily assume the risks associated with communicable diseases, including, but not limited to, COVID-19.

## **21 INSURANCE**

21.1 Each participating vessel must be insured with valid third-party liability insurance with a minimum coverage of Euro 1,500,000.00 per claim.

## **22 TROPHIES AND PRIZES**

22.1 The following trophies and prizes will be awarded:

22.2

- a. 1st boat at the Montecarlo finish line in real time.
- b. 1st boat at the Porto Rotondo Gate finish line in real time.
  
- c. 1st, 2nd and 3rd IRC Group A boats (if class will be split) finish in Monaco on corrected time.
- d. 1st, 2nd and 3rd IRC Group B boats (if class will be split) finish in Monaco on corrected time.
- e. 1st, 2nd and 3rd ORC Group A boats (if class will be split) finish in Monaco on corrected time.
- f. 1st, 2nd and 3rd ORC Group B boats (if class will be split) finish in Monaco on corrected time.
- g. First 3 classified at ORC Double Handed in corrected time
- h. Other prizes may be awarded at the discretion of the OA

### **CAGLIARI-MONACO TROPHY - FIRST LINE HONOR – PERPETUAL TROPHY**

**The trophy will be awarded to the first overall**

## **23 ENVIRONMENTAL RESPONSIBILITY**

Recalling the Basic Principle which mentions: "Participants are encouraged to minimize any negative environmental impact of the sport of sailing", the utmost attention to environmental protection is recommended in all moments that accompany the practice of the sport of sailing before, during and after the demonstration. In particular, attention is drawn to RRS 47 – Disposal of Waste – which literally states: "Competitors and support persons must not deliberately throw waste into the water. This rule always applies when in the water. The penalty for a breach of this rule may be less than disqualification."

## **24 MORE INFO AT LOA OFFICE/SEGRETERIA**

[www.cagliarimonaco.org](http://www.cagliarimonaco.org)

tel: +39 3407631845 (Direttore Sportivo LNI Cagliari)

email: [segreteria@cagliarimonaco.org](mailto:segreteria@cagliarimonaco.org)



# 1. ATTACHMENTS

## 1. A – CAGLIARI STARTING GATE AND POETTO BUOY

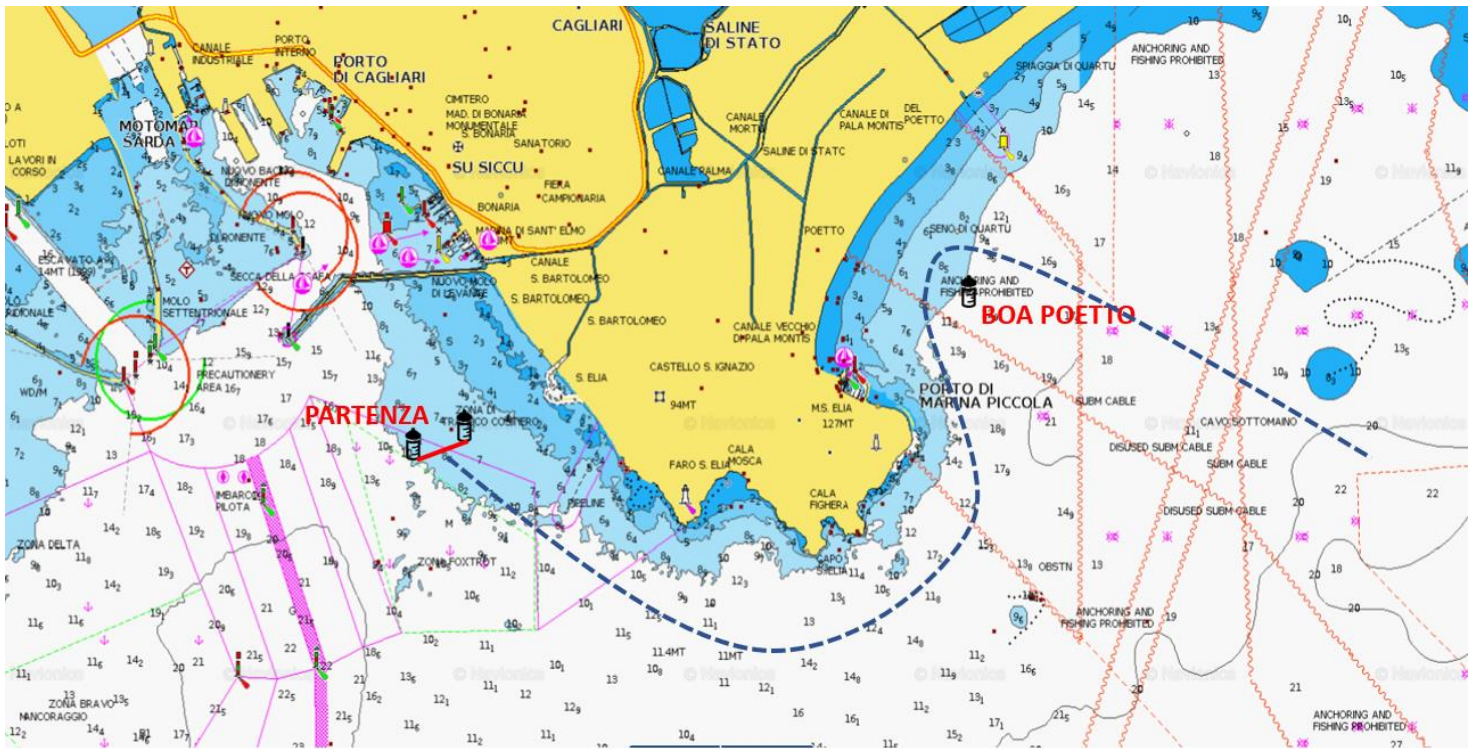

The Poetto buoy will be confirmed or not in the SI

## 2. B - PORTO ROTONDO NATURAL GATE

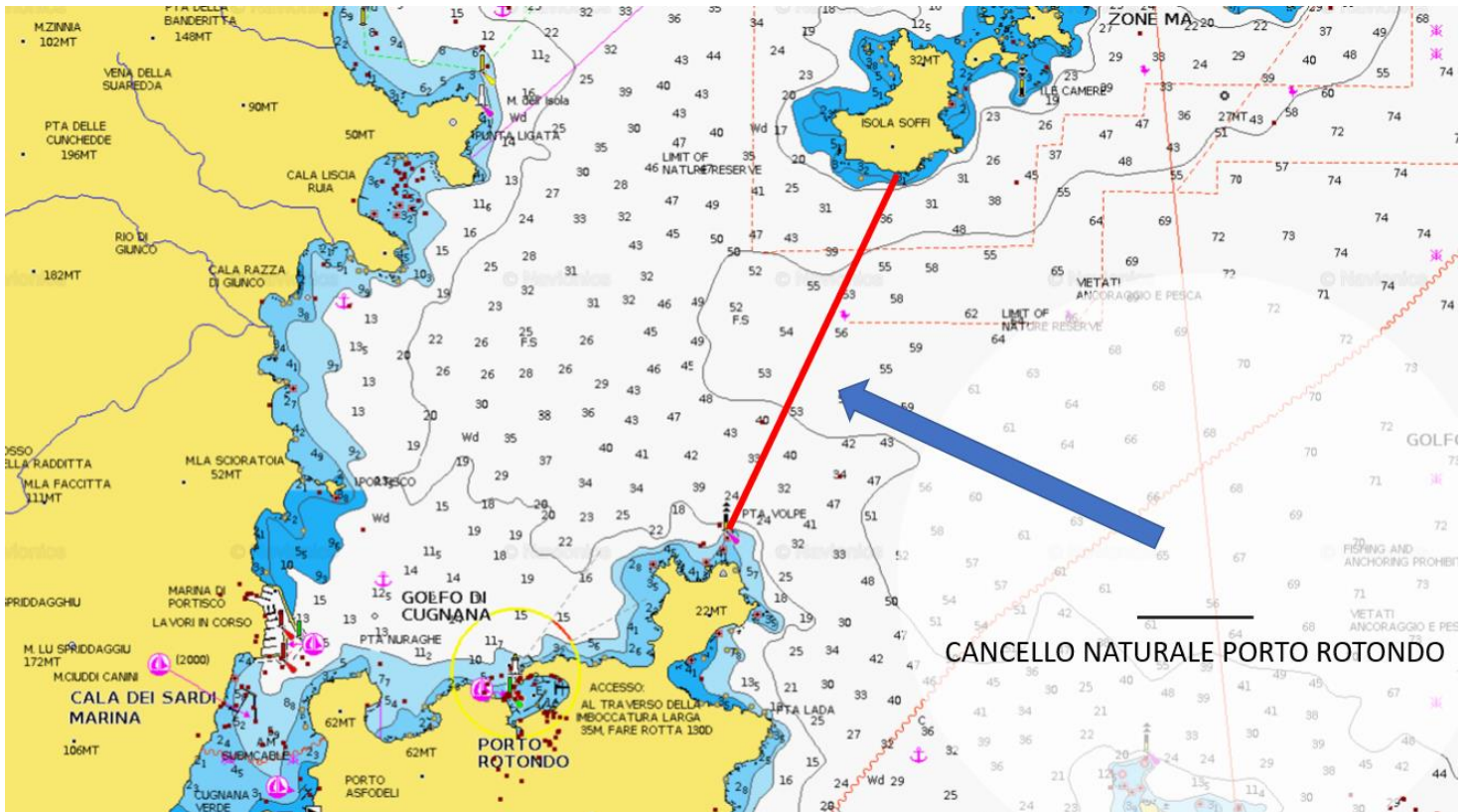

### 3. C – REGATTA COURSE



#### 4. D – MONACO FINISH GATE

### LINEA DI ARRIVO (Solo a scopo descrittivo)

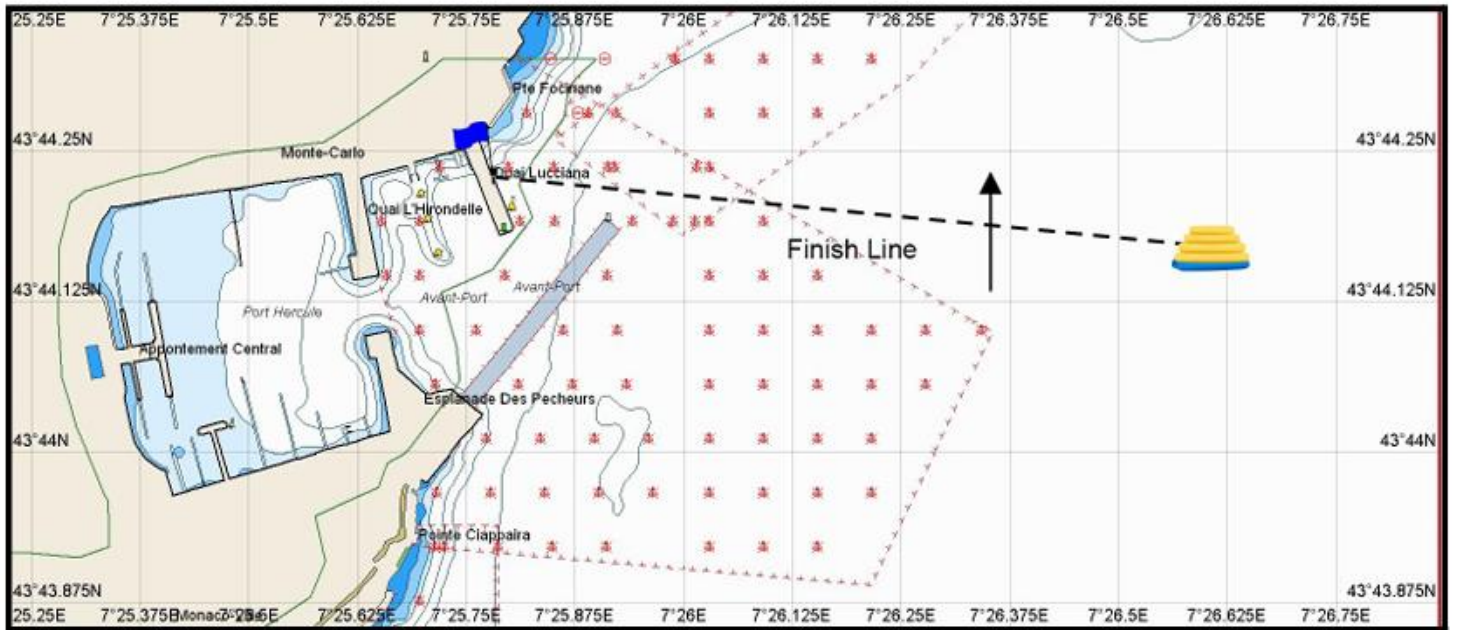

5. Allegato 5 - POSIZIONE ADESIVI UFFICIALI

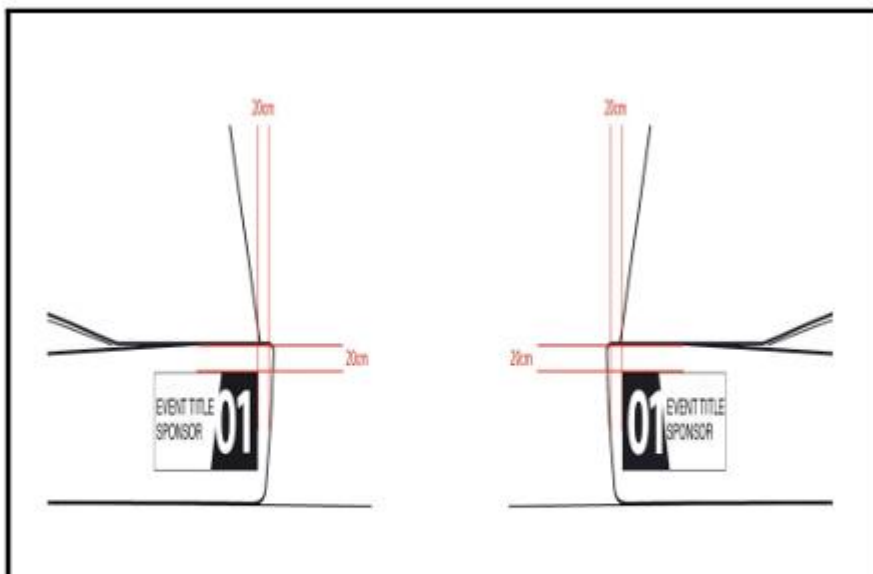

CORRETTO

ERRATO

